

# RLCSP1

Compression Canister, Stainless Steel Welded-seal, IP67, NTEP Certified 1:10,000 Class IIII Multiple Cell

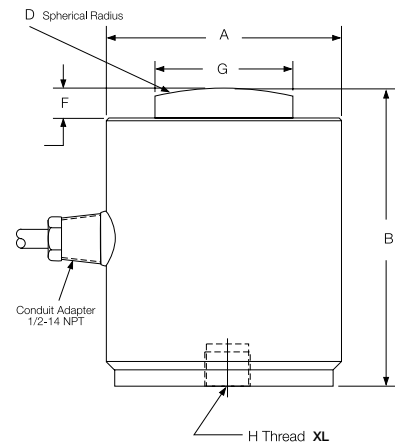

Picture is a representation of actual product



## Specifications

**Full Scale Output:**  
2.0 mV/V

**Output Resistance:**  
475.2-484.8 ohms

**Input Resistance:**  
445.5-454.5 ohms

**Material/Finish:**  
Stainless steel

**Temperature:**  
Compensated range  
14°F to 104°F/-10°C to 40°C  
Operating range  
-40°F to 150°F/-40°C to 65°C

**Safe Overload:**  
150% full scale

**Rated Excitation:**  
5-10 VDC (15 V maximum)

**Combined Error:**  
0.03% full scale

**Non-repeatability:**  
0.01% full scale

**Insulation Resistance:**  
1,000 megohms

**Deflection at Capacity:**  
25,000 lb-50,000 lb=0.003 in  
(0.076 mm)  
100,000 lb-200,000 lb=(0.006 in  
(0.152 mm)

**Seal Type:**  
Welded-seal, IP67

**Cable Length:**  
35 ft (10.7 m)

**Cable Diameter:**  
0.305 polyurethane jacket

**Cable Color Code:**

- Green .....+ Excitation
- Black.....- Excitation
- White .....+ Signal
- Red .....- Signal
- Orange ..... Shield

**Warranty:**  
Two-year limited warranty

**Approvals:**



## Dimensions

RATED CAPACITY	A	B	D	F	G	H	L-DEPTH
<b>lb/inches</b>							
25,000-50,000	3.00	3.25	6.00	0.40	1.25	1/2-20 UNF-2B	0.31
100,000	4.00	5.00	6.00	0.51	2.31	3/4-16 UNF-2B	0.56
200,000	6.00	7.25	17.00	1.04	3.13	3/4-16 UNF-2B	0.75
<b>kg/mm</b>							
11,339.8-22,679.6	76.2	82.6	152.4	10.2	31.8	1/2-20 UNF-2B	7.9
45,359.2	101.6	127.0	152.4	13.0	58.7	3/4-16 UNF-2B	14.2
90,718.5	152.4	184.2	431.8	26.4	79.5	3/4-16 UNF-2B	19.1

## Order Information

LOAD RATING		PART #	EST. SHIPPING WEIGHT	PRICE
25,000 lb	(11,339.8 kg)	32702	7 lb	\$1,795.00
50,000 lb	(22,679.6 kg)	32701	7 lb	1,795.00
100,000 lb	(45,359.2 kg)	32700	15 lb	2,100.00
200,000 lb	(90,718.5 kg)	32699	28 lb	2,995.00

## Interchangeable Products

MANUFACTURER	MODEL	PAGE #
VPG Sentsortronics®	65088-1000	—
VPG Revere®	CSP	292
VPG Revere	692B	—
Howe Richardson®	244699-000X	—
Streeter Amet®	3760XXX	—
<b>Weigh Module Available</b>		
Rice Lake Weighing Systems	MagnaMount®	104

# RLSCA-50K

Rocker Column, Stainless Steel Welded-seal, IP67, NTEP Certified 1:10,000 Class III Multiple Cell



Picture is a representation of actual product

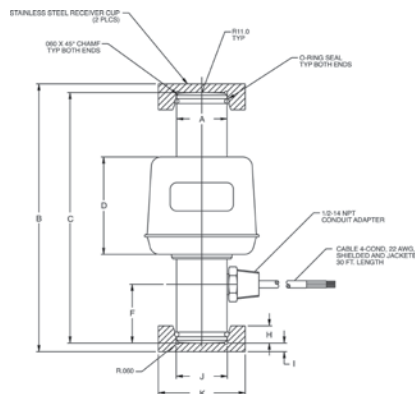

## Specifications

<b>Full Scale Output:</b> 2 mv/V nominal	<b>Temperature:</b> Compensated range 14°F to 104°F/-10°C to 40°C Operating range -40°F to 150°F/-40°C to 65°C	<b>Non-repeatability:</b> 0.01% full scale	<b>Cable Color Code:</b> Green .....+ Excitation Black.....- Excitation White .....- Signal Red .....+ Signal
<b>Output Resistance:</b> 1,050 (± 10) ohms	<b>Safe Overload:</b> 150% full scale	<b>Insulation Resistance:</b> 1,000 megohms	<b>Warranty:</b> Two-year limited warranty
<b>Input Resistance:</b> 1,100 ohms	<b>Rated Excitation:</b> 5-10 VDC (15 V maximum)	<b>Seal Type:</b> Welded seal, IP67	<b>Approvals:</b> 
<b>Material/Finish:</b> Stainless steel	<b>Combined Error:</b> 0.025% full scale	<b>Cable Length:</b> 30 ft (9 m)	
		<b>Cable Diameter:</b> 0.200 polyurethane jacket	

## Dimensions

RATED CAPACITY	A	B	C	D	F	H	I	J	K
<b>lb/inches</b>									
50,000	1.46	7.75	7.25	2.82	1.70	0.50	0.25	1.48	2.50
<b>kg/mm</b>									
22,679.6	37.0	196.8	184.1	71.6	43.1	12.7	6.35	37.5	63.5

## Order Information

LOAD RATING	PART #	EST. SHIPPING WEIGHT	PRICE
50,000 lb* (22,679.6 kg)	68918	7 lb	\$995.00
Replacement load cup set upper and lower included	85433	1 lb	95.00
Replacement O-rings	92988	1 lb	1.00/each

\*Load cell supplied with load cups

## Interchangeable Products

MANUFACTURER	MODEL
Cardinal®	SCA-50K

**NEW**

**RL70510-30†/RL80453-100,000 lb**

Rocker Cell, Stainless Steel, Hermetically Sealed, NTEP Certified 1:10,000 Class III L



Picture is a representation of actual product

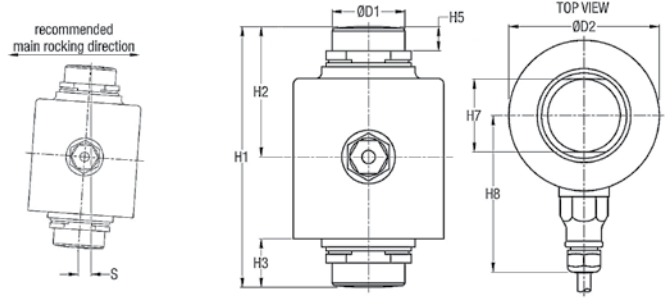

**Specifications**

**Full Scale Output:**  
2.0mV/v

**Output Resistance:**  
1,000 (± 2) ohms

**Input Resistance:**  
1,150 (± 50) ohms

**Material/Finish:**  
Stainless steel

**Temperature:**  
Compensated Range  
14°F-104°F/-10°C-40°C  
Operating range  
-40°F to 150°F/-40°C to 65°C

**Safe Overload:**  
200% full scale

**Rated Excitation:**  
5-10VDC (15V max.)

**Combined Error:**  
0.02% full scale

**Insulation Resistance:**  
5,000 megohms

**Seal Type:**  
Hermetically sealed

**Cable Length:**  
15 ft (4.5 m) stainless overbraid

**Cable Diameter:**  
0.200 overbraid cable

**Cable Color Code:**  
Green .....+ Excitation  
Black .....- Excitation  
White .....+ Signal  
Red .....- Signal  
Yellow ..... Shield

**Warranty:**  
Two-year limited warranty

**Approvals:**



**Dimensions**

RATED CAPACITY	H1	H2	H3	H5	H7	H8	D1	D2
<b>lb/in</b>								
30,000 kg	5.51	2.76	1.02	0.51	1.55	3.32	1.54	3.18
<b>lb/in</b>								
100,000 lb	5.91	2.95	1.30	0.51	1.54	3.32	1.54	3.18

**Order Information: RL70510**

LOAD RATING	PART #	EST. SHIPPING WEIGHT	PRICE
30,000 kg	169363	6 lb	\$965.00
Upper load cup	169364	4 lb	95.00
Lower load cup	170731	4 lb	95.00

**Interchangeable Products**

MANUFACTURER	PART #	MODEL
Fairbanks®	70510	LCF HR 4020-2A
Fairbanks	80453	LCF HR 4020-21

**Order Information: RL80453**

LOAD RATING	PART #	EST. SHIPPING WEIGHT	PRICE
100,000 lb	169365	6 lb	\$995.00
Upper load cup	169366	4 lb	95.00
Lower load cup	170732	4 lb	95.00

# RL75114-50K

Rocker Column, Stainless Steel Welded Seal, IP67, NTEP Certified 1:10,000 Class III L



Picture is a representation of actual product

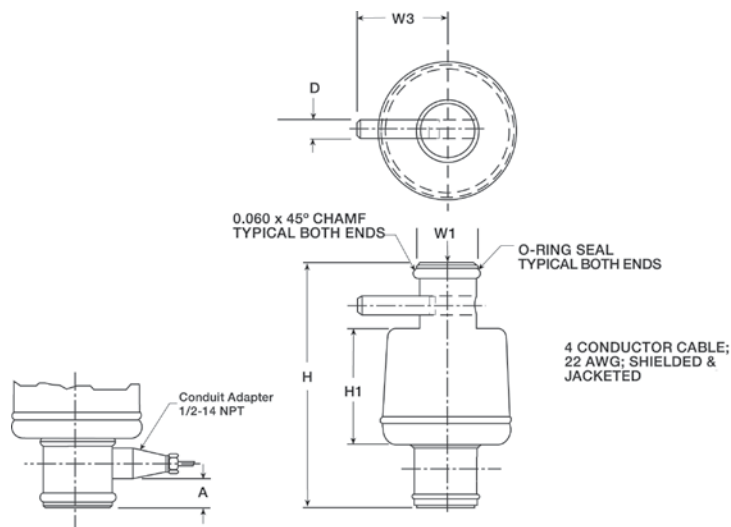

## Specifications

**Full Scale Output:**  
1.8 mV/v nominal

**Output Resistance:**  
1,000 (± 10) ohms

**Input Resistance:**  
1,000 ohms

**Material/Finish:**  
Stainless steel

**Temperature:**  
Compensated Range  
14°F-104°F/-10°C-40°C  
Operating range  
-40° F to 150° F/-40° C to 65° C

**Safe Overload:**  
150% full scale

**Rated Excitation:**  
5-10 VDC

**Combined Error:**  
0.025% full scale

**Non-repeatability:**  
0.01% full scale

**Insulation Resistance:**  
1,000 megohms

**Seal Type:**  
Welded Seal IP67

**Cable Length:**  
30 ft (9 m)

**Cable Diameter:**  
0.200 overbraid cable

**Cable Color Code:**  
Green .....+ Excitation  
Black .....- Excitation  
White .....+ Signal  
Red .....- Signal

**Warranty:**  
Two-year limited warranty

**Approvals:**



## Dimensions

RATED CAPACITY	A	D	H	H1	W1	W3
<b>lb/inches</b>						
50,000 LE*	0.87	0.38	7.56	2.82	1.46	2.18
<b>kg/mm</b>						
22,680.0	15.6	9.7	192.0	71.6	37.08	63.5

## Order Information

LOAD RATING	PART #	EST. SHIPPING WEIGHT	PRICE
50,000 lb (22,679.6 kg)	88074	6 lb	\$1,195.00
Replacement O-ring	92988	1 lb	1.00
Spring pin	116181	1 lb	5.00

\* LE refers to large envelope

Not interchangeable with Sensortronics 65114 - different mV/v

## Interchangeable Products

MANUFACTURER	PART #	MODEL
Fairbanks	64166	LCFHR4020-2

# RL8C2P1SS

Compression Canister, Stainless Steel Hermetically sealed, IP68, NTEP Certified 1:10,000 Class IIIIL Multiple Cell



Picture is a representation of actual product

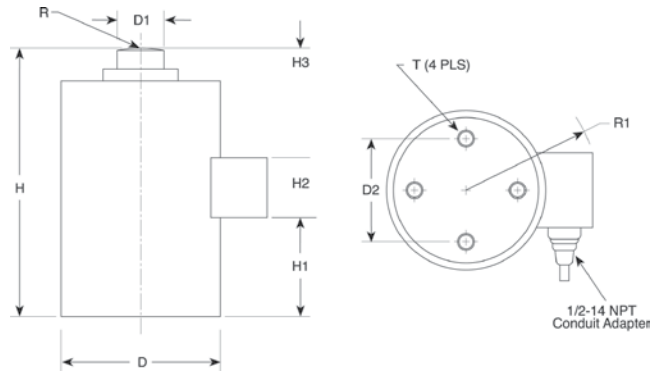

## Specifications

**Full Scale Output:**

2.0mV/V

**Output Resistance:**

350 (± 3.5) ohms

**Output Resistance:**

350 (± 3.5) ohms

**Material/Finish:**

Stainless steel

**Temperature:**

Compensated range  
14°F to 104°F/-10°C to 40°C  
Operating range  
-40°F to 150°F/-40°C to 65°C

**Safe Overload:**

150% full scale

**Rated Excitation:**

5-10 VDC (15 V maximum)

**Non-repeatability:**

0.01% full scale

**Combined Error:**

0.03% full scale

**Insulation Resistance:**

1,000 megohms

**Deflection at Capacity:**

50,000 lb=0.004 in (0.102 mm)  
100,000 lb=0.006 in (0.152 mm)  
200,000 lb=0.009 in (0.228 mm)

**Seal Type:**

Hermetically sealed, IP68

**Cable Length:**

35 ft (10.7 m)

**Cable Color Code:**

Green .....+ Excitation  
Black .....- Excitation  
White .....+ Signal  
Red .....- Signal  
Orange ..... Shield

**Warranty:**

Two-year limited warranty

**Approvals:**



## Dimensions

RATED CAPACITY	D	D1	D2	H	H1	H2	H3	R	R1	T
<b>lb/inches</b>										
50,000	4.50	1.25	2.38	7.50	1.17	0.75	0.75	8.00	3.75	3/8-24 UNF-2B x .63 D
100,000	5.75	1.75	4.00	9.13	2.00	0.87	1.05	12.00	4.05	1/2-20 UNF-2B x .75 D
200,000	7.50	2.50	5.50	11.63	2.93	0.97	0.97	12.00	5.11	5/8-18 UNF-2B x 25.4 D
<b>kg/mm</b>										
22,679.6	114.3	31.8	53.4	190.5	77.7	19.1	19.1	203.2	95.3	3/8-24 UNF-2B x .63 D
45,359.2	146.1	44.5	101.6	231.9	66.0	22.1	26.6	304.8	102.9	1/2-20 UNF-2B x .75 D
90,718.5	190.5	63.5	139.7	295.4	100.0	24.6	24.6	304.8	129.8	5/8-18 UNF-2B x 25.4 D

## Order Information

LOAD RATING	PART #	EST. SHIPPING WEIGHT	PRICE
50,000 lb (22,679.6 kg)	34855	20 lb	\$2,195.00
100,000 lb (45,359.2 kg)	34856	36 lb	2,195.00
200,000 lb (90,718.5 kg)	34857	75 lb	3,395.00

## Interchangeable Products

MANUFACTURER	MODEL	PAGE #
VPG Revere®	792	293